

CSO/STORMWATER MANAGEMENT

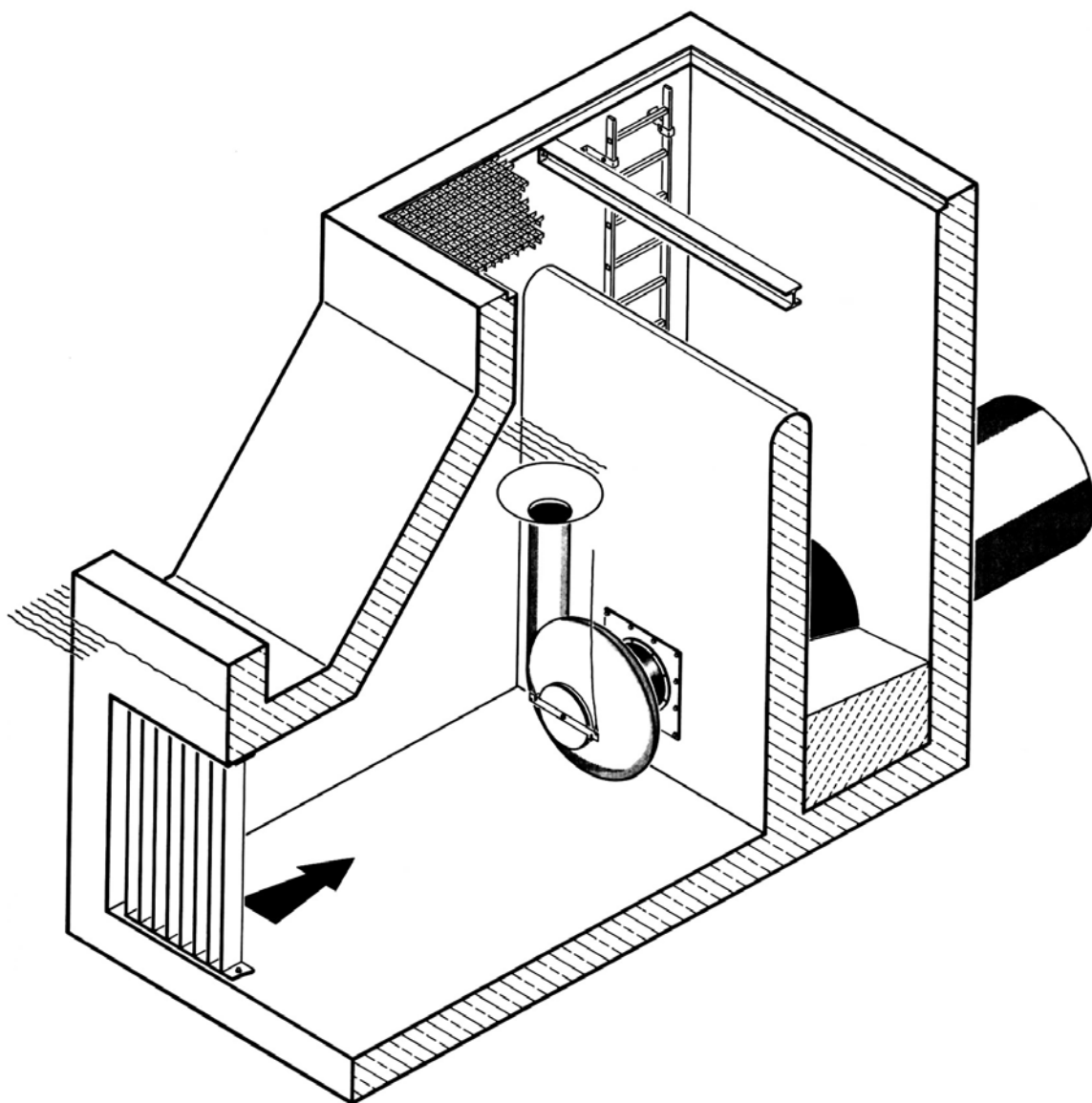

 [®] HYDROVEX [®]

Pond Vertical Vortex
Flow Regulator



JOHN MEUNIER

HYDROVEX® POND VERTICAL VORTEX FLOW REGULATOR

APPLICATION

The **HYDROVEX® Pond** Vertical Vortex Flow Regulators are a version of the large family of vortex flow regulators. They operate without moving parts or external energy. The regulation of flow happens only under the effect of the flow (Fluidic). These units can create important restrictions while keeping a large open section for the flow.

The **HYDROVEX® Pond** Vertical Vortex Flow Regulators are designed for installation on small retaining tanks or water ponds. These basins can simultaneously fulfill the role of separator of floating matters when the installation includes a baffle hood at the inlet of the regulator chamber or a hood immersed on the inlet tube of the unit.

AVANTAGES

- Large open section for the flow
- No moving parts
- Minimum wear
- Does not require any external energy
- Great operational safety
- Anti-corrosion materials, great longevity
- Precise regulation of flow
- Easy and quick assembly
- No adjustment to be carried out
- Typical “S” shape flow curve
- Acts as a permanent controlled overflow in the basin

OPERATION

The vortex chamber of the **HYDROVEX® Pond** Vertical Vortex Flow Regulator is installed vertically, ex: the discharge of the unit is done horizontally downstream from the basin. The inlet tube is vertical and connected tangentially to the main body (**Figure 1**).

The weir created by the funnel of the unit defines the basin’s water level. In special constructions, the regulator can be equipped with an adjustable telescopic funnel.

The **HYDROVEX® Pond** Vertical Vortex Flow Regulator has a wall mounting plate anchored to the basin’s back wall, in line with the discharge opening. A joint seals the plate to the wall.

In general, the unit is shop adjusted to the design flow. If required, a removable orifice can be installed, allowing later modification of the flow characteristics.

As a complementary option, each unit is supplied with an emergency bypass activated by a rope. Once the emergency bypass is opened, it is possible to drain most of the basin. The rope and bayonet system allows for the opening only of the unit. It must be closed manually after inspection.

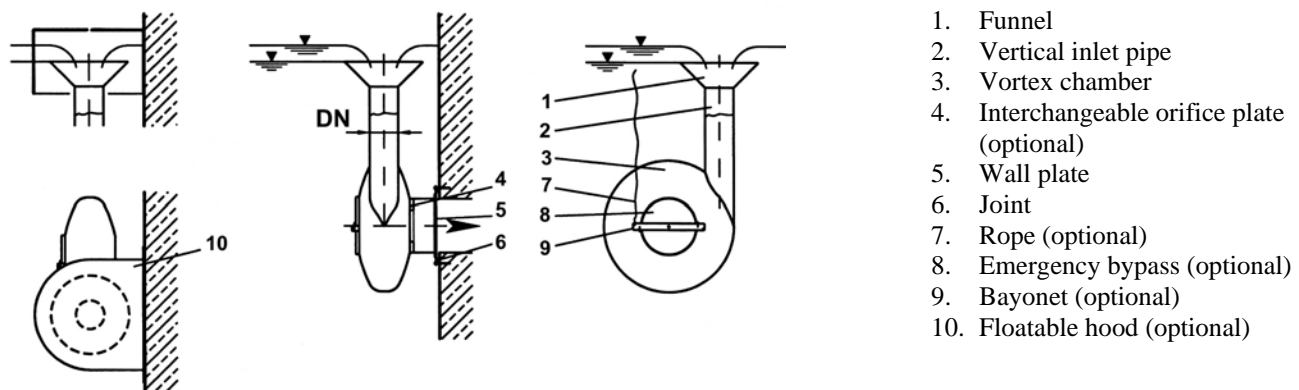

Figure 1: Components of a Hydrovex® Pond Vertical Vortex Flow Regulator

HYDRAULIC BEHAVIOR

The hydraulic behavior of the **HYDROVEX® Pond Vertical Vortex Flow Regulator** relates to **Figure 2**. The regulator is located in a chamber at the output point of a pond or basin. The upstream basin acts as a floating material separator.

The unit typical flow curve of the regulator is shown on **Figure 2**. The dotted line portion represents the flow pattern that actually never happens; only the small section of vertical curve "a" is present. The length of admission pipe at the unit inlet causes this. Once the water enters the vortex unit, the pressure head is already large enough to create the full vortex.

The first flat part of curve "b" is produced by discharge of the funnel, acting as an overflow weir. The other part "c" of the curve comes from the emergency overflow of the chamber.

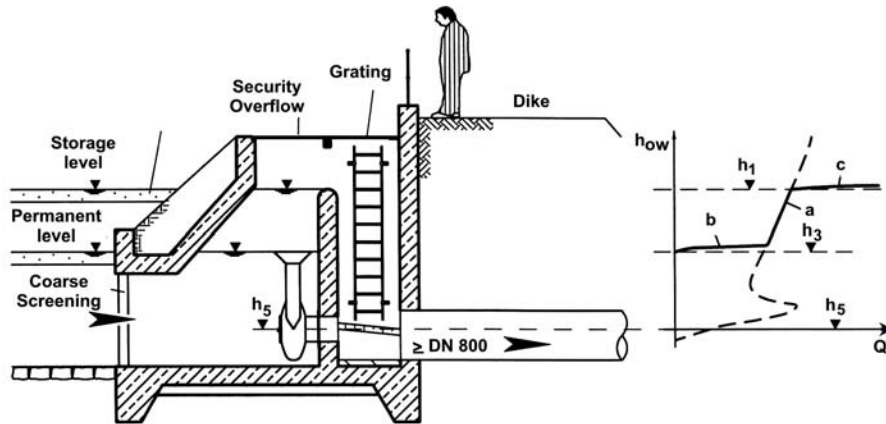

Figure 2: Example of installation of a Hydrovex® Pond Vertical Vortex Flow Regulator. Left, the retention tank and regulator chamber, and right, the flow curve.

HYDRAULIC DIMENSIONING

The hydraulic dimensioning of the **HYDROVEX® Pond Vertical Vortex Flow Regulator** is based on the curve characteristics of the **HYDROVEX® SVHV Vertical Vortex Flow Regulator**, which was the subject of laboratory hydraulic tests in 1996 /2/.

For a complete dimensioning, the dimensions presented on **Figure 3** are required. For retention tanks, the design flow Q can be taken equal to the arithmetic mean between the flow at the beginning of storage and the flow at the maximum level /3/. The head is measured starting from the axis of the vortex unit h_5 . For a preliminary sizing, the minimum and maximum flow values can be taken from **Table 1**. All values are valid for a head of $h_b = 6' - 6''$ (2m).

All regulators are shipped ready for installation. We guarantee a precision of flow of $\pm 10\%$ for the design head. The unit is shop adjusted to the design flow. No site adjustment during installation is required.

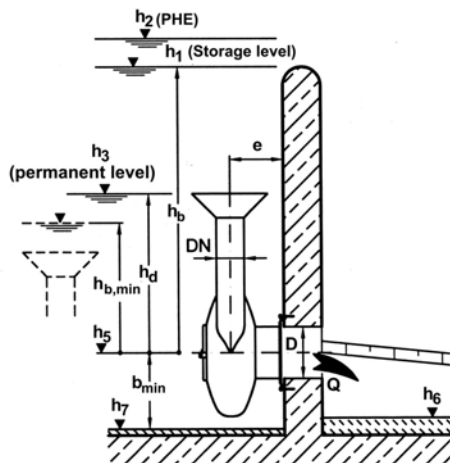

Figure 3: Definition of height, water level and flow rate

DN mm (in.)	Q_{min} (type 4) l/s (cfs)	Q_{min} (type 3) l/s (cfs)	$H_b min$ (type 4) m (ft.)	D mm (in.)	B_{min} (type 4) mm (in.)	e mm (in.)
50 (2")	2.2 (0.1)	4.7 (0.2)	0.2 (0.7')	100 (4")	150 (6")	150 (6")
80 (3")	5.4 (0.2)	11.7 (0.4)	0.32 (1.1')	160 (6")	240 (9")	180 (7")
100 (4")	8.3 (0.3)	18 (0.6)	0.4 (1.3')	200 (8")	300 (12")	200 (8")
125 (5")	12.8 (0.5)	27 (1.0)	0.5 (1.6')	250 (10")	375 (15")	225 (9")
150 (6")	18.2 (0.6)	39.8 (1.4)	0.6 (2.0')	300 (12")	450 (18")	250 (10")
200 (8")	32.1 (1.1)	70.1 (2.5)	0.8 (2.6')	400 (16")	600 (24")	300 (12")
250 (10")	50.1 (1.8)	109.3 (3.9)	1 (3.3')	500 (20")	750 (30")	350 (14")
300 (12")	71.9 (2.5)	157 (5.5)	1.2 (3.9')	600 (24")	900 (35")	400 (16")

Table 1: Flow rates for $h_b = 6' - 6''$ (2 m), minimum charge and sizing according to Figure 3.

MATERIAL AND GUARANTEE

HYDROVEX® Pond Vertical Vortex Flow Regulators are designed to be used both in storm drainage and in wastewater. We use only stainless steel and plastics for manufacturing. Any additional corrosion protection is not required. The unit operation precision is guaranteed for a five-year period.

INSTALLATION

The installation of the **HYDROVEX® Pond** Vertical Vortex Flow Regulator is very simple. The equipment is delivered ready to install with all the seals and anchors.

You must supply us the permanent retention elevation in the basin before delivery, as the unit will be constructed accordingly. The funnel and the length of the tube will be fabricated for this elevation. The wall plate is placed in position for installation. The Axis of the outlet orifice must fit perfectly with the axis of the opening in the wall and the inlet pipe must be vertical. The unit is anchored to the wall with stainless steel anchors, delivered with the unit. All anchors must be tightened diagonally, at the same torque, not too strongly, to prevent seal breaking or damage.

The emergency bypass plate, supplied in option, is then installed and tested. The end of the pull rope is to be hung above the maximum water level, in an easy to access location.



Figure 4: HYDROVEX® Pond Vertical Vortex Flow Regulator, Type 3, DN 200 (8'') without bypass cover, ready for installation.

John Meunier Inc.

ISO 9001 : 2000

Head Office

4105 Sartelon
Saint-Laurent (Quebec) Canada H4S 2B3
Tel.: 514-334-7230 www.johnmeunier.com
Fax: 514-334-5070 cs@johnmeunier.com

Ontario Office

2000 Argentia Road, Plaza 4, Unit 430
Mississauga (Ontario) Canada L5N 1W1
Tel.: 905-286-4846 www.johnmeunier.com
Fax: 905-286-0488 ontario@johnmeunier.com

USA Office

2209 Menlo Avenue
Glenside, PA USA 19038
Tel.: 412-417-6614 www.johnmeunier.com
Fax: 215-885-4741 astele@johnmeunier.com